



Technical data

LOG AND CANT CIRCULAR RESAW VNK

Technical data VNK 300 / VNK 360

Sawing height	mm	75-310 (VNK 360 75-360)
Log/cant length min.	m	2.4
Saw arbor length fix mounted saws per side	mm	115
Saw arbor diameter	mm	240
Machine opening outfeed unit max.	mm	700
Saw blade diameter top and bottom	mm	610 (*655)
Feed speed max.	m/min	140
Drive motors	kW	4x110 - 4x200 (at 1500 1/min)
Machine weight with drive motors	t	20

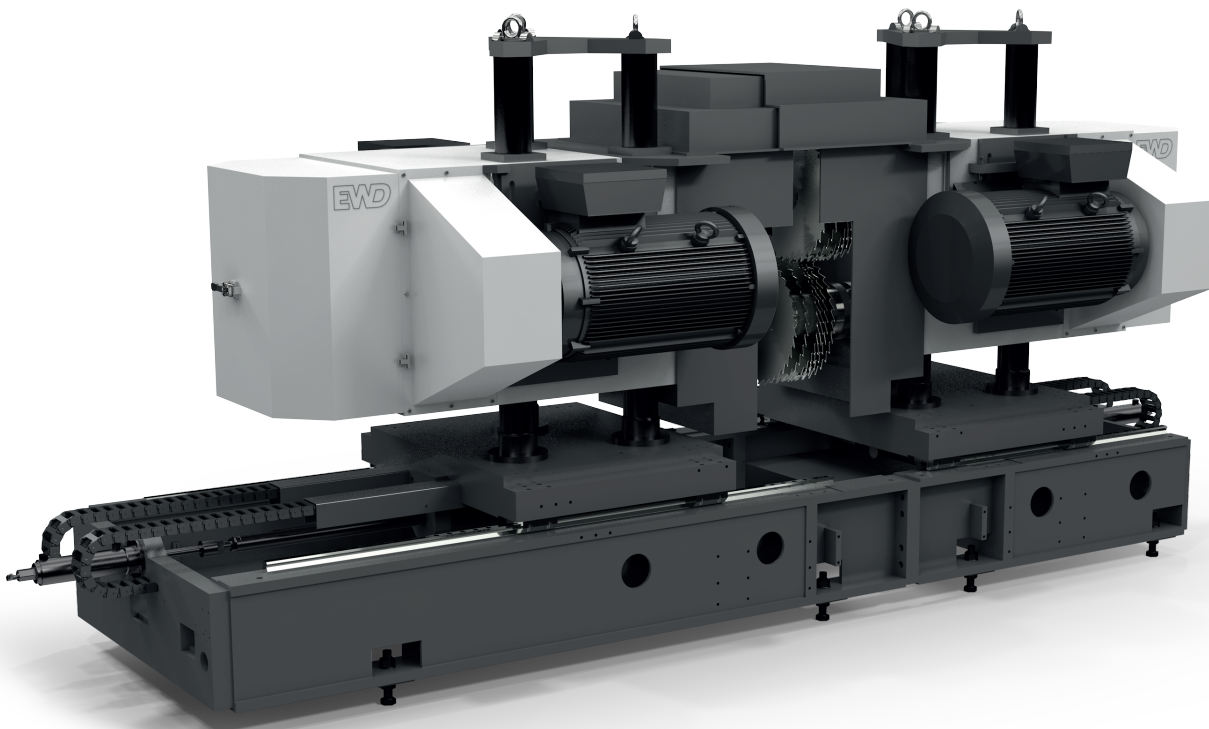

As a result of constant improvement and further development of our designs, the information and illustrations in this brochure are not binding.



Technical data

SAW SETTING DISTANCES (in mm)

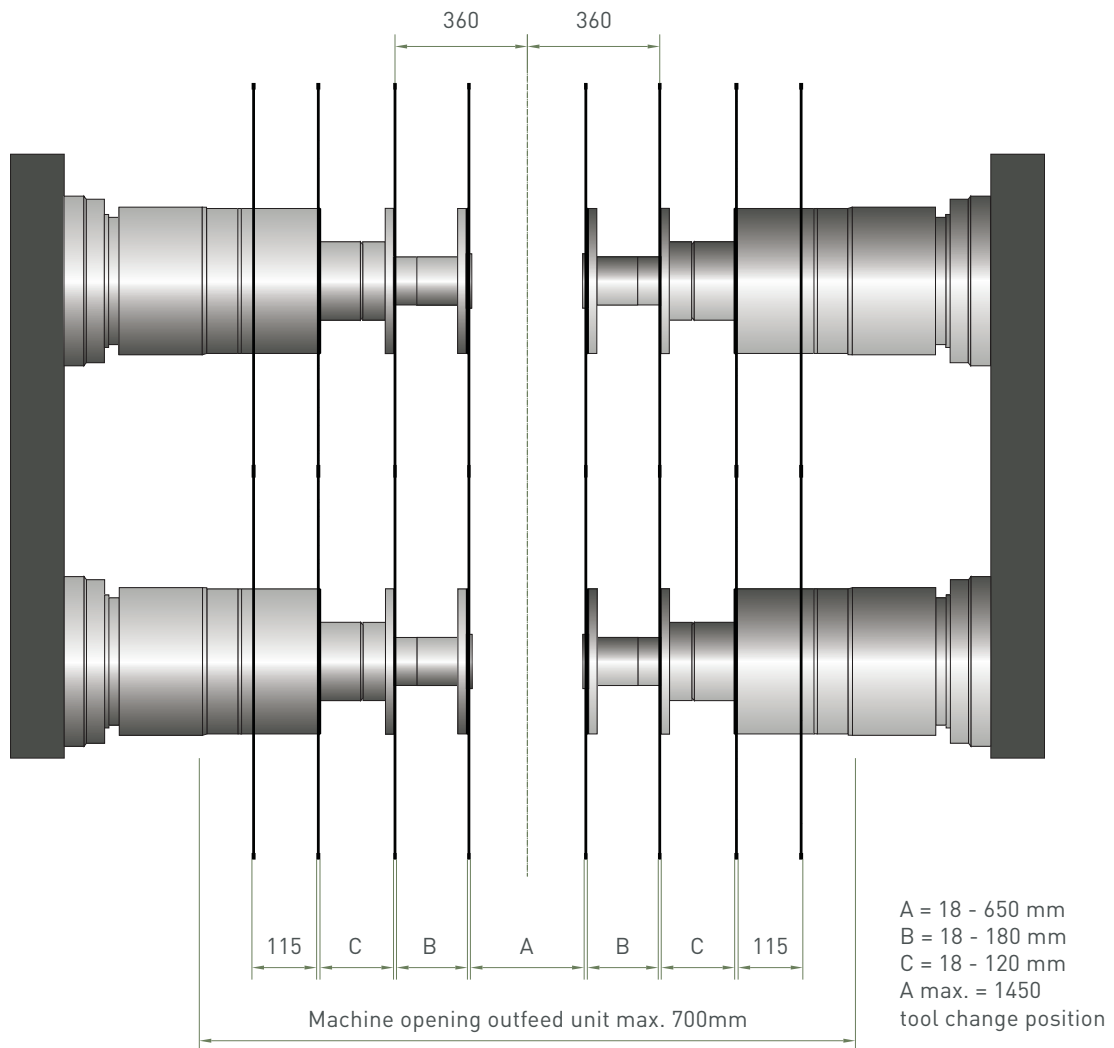

As a result of constant improvement and further development of our designs, the information and illustrations in this brochure are not binding.